

DC Accessories

POWER CABLES, LOOMS, FUSES, CONNECTORS & COVERS



Flexible power cables

These cables are manufactured from high performance switchgear multi-strand wire, sheathed in either red or black PVC. They are extremely flexible allowing easy routing around the vehicle. Each cable is terminated at both ends with heavy duty copper ring terminals and heat-shrink tubing providing a good seal from water ingress.



Generous sizing ensures low voltage loss thereby improving charging, and other problems associated with voltage drops.

Four basic sizes are offered; 25mm², 35mm², 50mm² and 70mm². Each cable is priced at 1m and other lengths based upon the cost per meter of uncut cable. Additional protection can be offered using sheaths which are priced per metre.

The key to a successful auxiliary power system is to specify the correct accessories. Over the years Antares have used selected components which have proved their worth on specialised vehicles.

The accessories range includes highly flexible heavy duty cables, high current fuses, large terminal covers and rugged DC DC connectors. All specified to fit together to create a reliable and effective auxiliary electrical power system. Antares can supply complete wiring loom assemblies as part of ant solution.

Terminal and stud covers

The range comprises of three rubber boot covers: small stud terminal cover, large stud terminal cover, and battery terminal cover.

High current stud fuses

This unique range allows the location of the fuse directly onto a battery terminal or a stud and can be used in a variety of configurations. Fuse ratings of 125A to 300A are available matched to cable sizes

DC power connectors

It is often required to disconnect equipment or batteries, for transportation, night charging or servicing. Any two cables up to 50mm² can be specified with an 175A connector as a termination. An optional A frame handle is available if the connector is to be used regularly.

Support

Please call one our applications engineers if you need any assistance. We have had a lot of experience applying these products and can often suggest alternative ways to achieve an optimal solution.



FM 37786
ISO 9001:2008



Antares (Europe) Limited
Knaves Beech Business Centre
Davies Way
Loudwater
HIGH WYCOMBE
HP10 9QR UK

www.antares.co.uk
email: info@antares.co.uk
tel: +44 (0)1628 535440
fax: +44 (0)1628 535441





ANTARES
engineering with answers

DC Accessories

POWER CABLES, FUSES, CONNECTORS & COVERS



POWER CABLE SELECTOR	Assembled Cable (1m)	Uncut Cable/m	Outer Conduit/m	Current Rating (cont)	Resistivity milliohms per metre	Diameter Cable mm	Diameter Conduit mm
							
POWER CABLE 25MM ² RED	80185	49296	60092	136A	0.70	10.6	16
POWER CABLE 25MM ² BLK	80197	49096	60092	136A	0.70	10.6	16
POWER CABLE 35MM ² RED	80188	49276	60093	167A	0.50	12.2	20
POWER CABLE 35MM ² BLK	80200	49076	60093	167A	0.50	12.2	20
POWER CABLE 50MM ² RED	80191	49239	60093	190A	0.35	14.0	20
POWER CABLE 50MM ² BLK	80203	49039	60093	190A	0.35	14.0	20
POWER CABLE 70MM ² RED	80194	49260	60122	240A	0.22	16.5	25
POWER CABLE 70MM ² BLK	80206	49060	60122	240A	0.22	16.5	25

Temperature rating: 105°C, heat resistant to 105 °C and oil resistant to 60°C
 Voltage Rating: 600V, insulation 0.8mm heat resistant PVC
 Construction: Assembled cables are completed with crimped 8mm heavy duty copper ring terminals with heatshrink tubing.
 Standards: UL1283/4, CSA TEW and BS6231 Type CK
 Outer sheath (when specified): Black flexible conduit

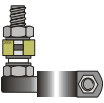
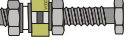
			
STUD TERMINAL COVER SMALL BLACK	STUD TERMINAL COVER LARGE BLACK	BATTERY POST COVER 70MM DIAMETER BLACK	BATTERY POST COVER 70MM DIAMETER RED
60039	60038	60033	60225
Application: studs with 25mm ² cable	Application: studs with light 35mm ² and 50mm ² cable	Use: battery posts and studs with 70mm ² cable	Use: battery posts and studs with 70mm ² cable

HIGH CURRENT STUD FUSE							
Fuse rating		125A	150A	175A	200A	250A	300A
Cable size		25mm	35mm	50mm	70mm	95mm	120mm
FUSE (REPLACEMENT)		65153	65154	65155	65156	65157	65158
FUSE CLAMP KIT 8MM STUD		98125	98150	98175	98200	98250	98300
FUSE BOLT KIT 8MM STUD		98126	98151	98176	98201	98251	98301

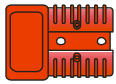
Kit comprises: battery clamp or bolt, fuse, nut, washer, insulator and installation instructions. Note that 10mm ring terminals must be used. Please advise if ordering completed cables.

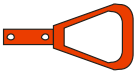
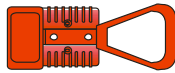
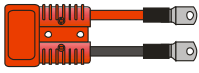
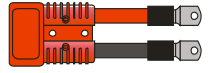
DC POWER CONNECTORS AND ASSEMBLIES 175A – suitable for cables 35 and 50mm ²					
					
CONNECTOR (SB175A/2 POLE) Suitable for 50mm ² cable	REDUCER 50/35MM² To convert 64040 to 35mm ² cable (2req)	A FRAME HANDLE SB175A For 64040	CONNECTOR (175A/2 POLE/ HANDLE) + FITTING	POWER ASSY (175A/35MM² /1M)	POWER ASSY (175A/50MM² /1M)
64040	64048	64041	70215	98011	99922

Features: continuously rated, 600V, colour red, polycarbonate material