

Automatic Aux 12 charger

12V AUXILIARIES TOP-UP CHARGER + INTEGRAL SPLIT CHARGE



Approved condition for use :
On-board road going vehicles

A wide variety of equipment, equipped with 12V batteries, is used on 24V vehicles.

These provide starting, safety backup, or low duty power and these need to be in tip-top condition so that when called upon to perform they will not let you down.

The Automatic Aux 12 Charger is designed to provide a small "top-up" charge.

It also protects the 24V system from discharge via an in-built split charge which only operates when it recognises a 24V battery charger or engine alternator running

This all in one charger is easy to fit, and can be universally fitted to 24V chassis

The unit is designed, built and supported by Antares in the UK.

Key features

- 1.8A current output
- No fan, no moving parts
- 24V input
- Integral automatic split charge ensures main batteries cannot be depleted
- Overload protected
- Rugged construction in aluminium casing and conformal coating on PBA to protect against corrosion.
- Stable fully regulated output
- Suitable for GEL and AGM batteries
- Specialist version for Light Portable Pump batteries
- Simple flange mounting
- Two year warranty

Where are they used?

Float charge start batteries on....

- Light portable pumps
- Petrol & diesel Generating sets
- Truck mounted Forklifts

Light duty cyclic applications where the average load is less than 1.8A.....

- GPS/Asset Management
- Radio Communications
- Stair walkers

Rugged environmental protection

The unit is IP20 rated. It has no cooling fan, relying instead on efficient external cooling.



FM 37786
ISO 9001:2008

Antares (Europe) Limited
Knaves Beech Business Centre
Davies Way
Loudwater
HIGH WYCOMBE
HP10 9QR UK

www.antares.co.uk
email: info@antares.co.uk
tel: +44 (0)1628 535440
fax: +44 (0)1628 535441

ANTARES
engineering with answers

Automatic Aux 12 charger

12V AUXILIARIES TOP-UP CHARGER + INTEGRAL SPLIT CHARGE

This avoids drawing contaminated and salt laden air across the components

The printed circuit boards are conformally coated to aerospace standards, protecting against high humidity. Vibration damage is guarded against with through-plated PBA's and careful component mounting.

Call us!

Need more power? Do you need a different control regime? Antares offer a full range of the shelf DC charging devices and power supplies.

The range also includes

- High Current DC Chargers
- High Current DC Equalisers
- High Current DC convert
- Active Line Chargers

As designers we can customize any of these products to the exact requirements or your application.

Antares support

Antares have a reputation for supporting our customers and products, taking great pride giving engineering service. Whether you buy directly from us, through one of our distributors, or have our equipment specified on your vehicles we are there to support you.

You can be assured of help with applications, installation, servicing and design. Put this to the test - we look forward to working with you.

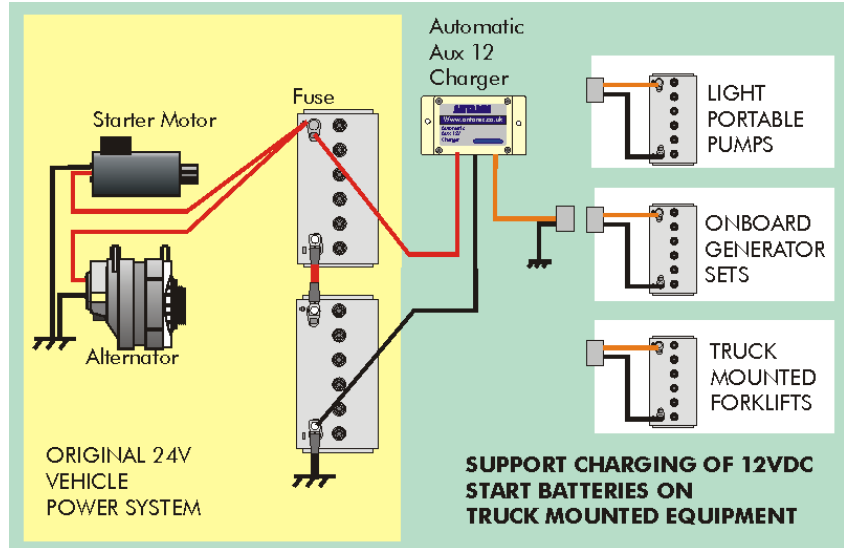

TECHNICAL SPECIFICATIONS

System voltage	24VDC
(Part No 13.2V version)	90152 (Suitable for 12V battery used on Godiva Light Portable pump)
(Part No 13.6V version)	90153 (Suitable for Lead Acid, GEL, AGM or standard flooded batteries)
Output voltage	13.2VDC or 13.6VDC +/- 0.1VDC
Output current	1.8A
Power draw	Negligible in sleep mode <5mA
On/of control	automatic on @ 26.0VDC +/- 0.15V automatic off @ 25.2VDC +/- 0.15V Detects charger/alternator
Dimensions	140mm (incl flanges) x 67mm x 34mm
Weight	0.25kg
Enclosure	Powder Coated Aluminium
Enclosure Protection	IP Rating 20
System Protection	Overcurrent Reverse current drain
Connection	Flying Leads 1m long, 1mm ² red - 24V battery positive supply Yellow - 12V battery positive black - to common neg.
Environment	-20 to +50°C, 0 to 95% RH